

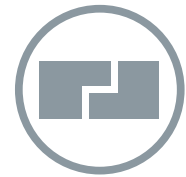

## RIGID EXTRUDED POLYSTYRENE (XPS) FOAM BOARD FOR THERMAL INSULATION OF INVERTED ROOFS AND FLOORS



Ship-lap edge



Thermal insulation



Negligible long-term water absorption

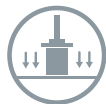

High compressive strength



High durability



Inverted roof systems



Recyclable boards



Environmental Product Declaration

DANOPREN® TR is a rigid extruded polystyrene (XPS) foam board with ship-lap edges at various thicknesses. Manufactured without CFC's, HCFC's or HFC's.

### ADVANTAGES

- Easy and safe handling: they are light, do not irritate the skin, do not give off dust, and maintain their physical integrity.
- Negligible long-term water absorption.
- Long-term high compressive and mechanical strength.
- Durability equal to the service life of the building within which they are incorporated.
- Recycling and the re-use of DANOPREN® XPS insulation is feasible depending on system installed.
- Additional protection from mechanical damage and thermal shock when installed on top of the waterproofing system and subsequent DANOFLOW® water flow reducing layer.

### APPLICATIONS

- Thermal insulation for flat roofs, both conventional and inverted.
- Thermal insulation for floors with overloads, for residential and commercial use.

### PRODUCT RANGE

Trade name	Thickness (mm)	Conductivity (W/m·K)	m <sup>2</sup> /bundle	Panels/bundle
<b>DANOPREN® TR</b> 1,25 x 0,60 m	30	0,033	10,50	14
	40	0,034	7,50	10
	50	0,034	6,00	8
	60	0,034	5,25	7
	80	0,036	3,75	5
	100	0,037	3,00	4



## INSTALLATION

### Inverted roofs

- A suitable separation layer like DANOFELT® PY 150 shall be installed between the DANOPREN® TR boards and the waterproofing membrane if it's a PVC membrane the separation layer should be like DANOFELT® PY 300.
- DANOPREN® TR boards shall be installed loose-laid, with staggered joints between successive rows and with all their joints tight.
- When close to every detailing, the boards will form the joint with at least a 5 mm tolerance.
- Depending upon the specification, a suitable separation layer like DANOFELT® PY 300 shall or alternatively our DANOFLOW® Water Flow Reducing Layer should be installed between the boards and the ballast (gravel or paving).
- It shall be avoided any ballast that may form a tight vapor diffusion layer on top of the boards.

### Residential and commercial floors

- The structural deck must show proper leveling and flatness
- DANOPREN® TR boards must be installed loose-laid, with tight and staggered joints between successive rows.

- In the case of slab insulation, DANOPREN® TR boards may be placed directly onto the ground, once the soil is properly compacted. If a plastic film is installed as a watertight barrier, it is recommended to place it above the DANOPREN® TR boards.
- A screed of at least 40 mm thickness will be installed, as a bed layer for the pavement, above the DANOPREN® TR boards. For light or adhered flooring finishings, a minimum 30 mm screed is recommended, reinforced at least with a 220 g/m<sup>2</sup> mesh.
- In case of heating floor systems the boards must be placed below the heating system.

## STORAGE AND PRESERVATION

- Do not expose to temperatures exceeding 75 °C.
- They must be protected from direct sunlight during storage for long periods of time.
- They can be stored outdoors, unaffected by rain, snow or ice.

## COMPATIBLE SOLUTIONS

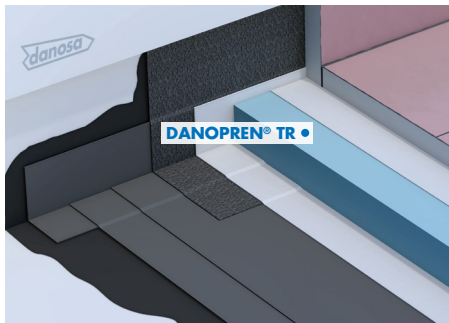

Built-Up Felt flat roof system

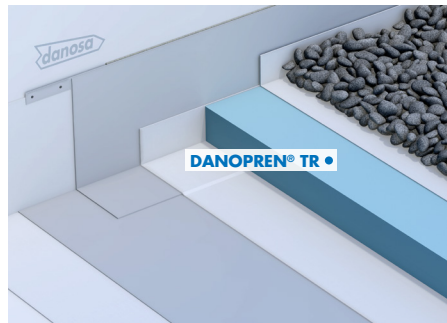

Not passable inverted flat roof

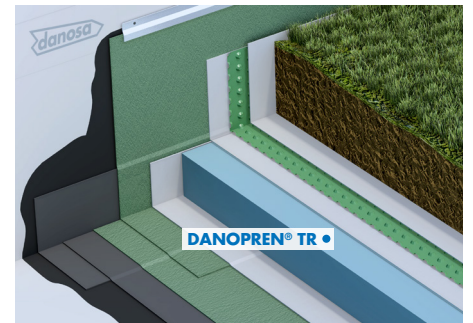

Intensive landscaped flat roof

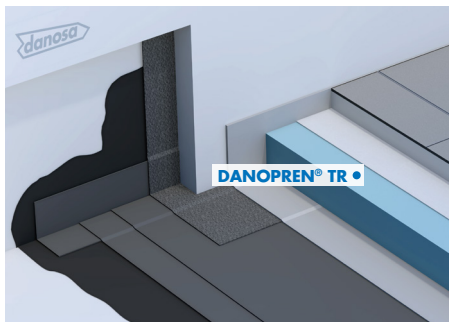

Technical acoustic flat roof



Buried walls

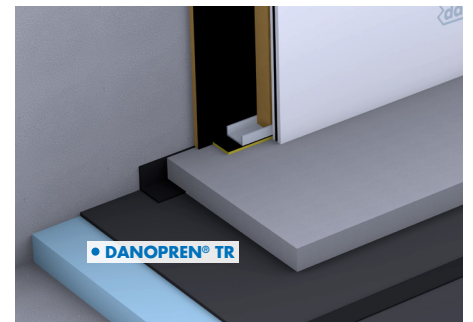

Thermoacoustic basic floating floor

